

TRIPLE A PLUS™

SAFETY HAS NO PRICE

marathon

TRIPLE A PLUS™

THE ULTIMATE PROTECTION SLEEVE FOR TEXTILE SLINGS

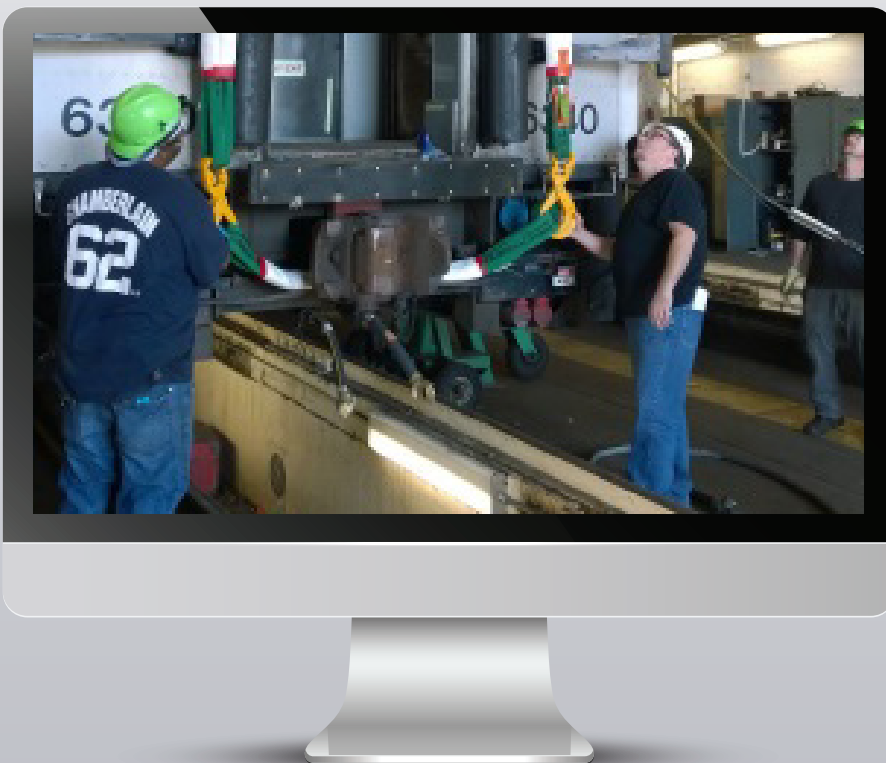

PROVIDING ENHANCED RESISTANCE TO ALL FORMS OF CUT AND ABRASION

Synthetic sling failure caused by cut and abrasion can result in high value products being damaged, create production issues incurring costly delays and in extreme cases cause personal injury and death.

The Triple A Plus™ sling protection sleeve made with Dyneema® fibre and manufactured by the World's leading producer of multi-ply textile products, Marathon, is making lifting slings safer and helping organisations to avoid such risks.

ADVANCED SLING PROTECTION



The demand for user-friendly textile slings to substitute heavy steel slings is constantly growing. Since the introduction of High Performance Fibres the lifting capacity range of textile lifting slings has increased considerably, allowing them to compete with steel slings also in the higher load spectrum.

The challenge remains to accommodate the negative effects of chafing and cutting, occurring in lifting applications, which could cause catastrophic and costly sling failures.

The solution is Triple A Plus™ by Marathon. It provides advanced sling protection where enhanced resistance to all forms of cut and abrasion is required and safety is a necessity.

BENEFITS INCLUDE;

- Excellent resistance to sharp edges
- Outstanding abrasion resistance when under extreme pressure
- Exceptional flexibility as expected from a textile product
- Very significant improvement in the safety of lifting apparatus

PROPERTIES

THE NO1 SOLUTION WHEN HEALTH & SAFETY
CANNOT BE COMPROMISED



Raw Material

The Triple A Plus™ sleeve is manufactured using Dyneema, an Ultra- High Molecular Weight Polyethylene (UHMwPE) yarn invented and produced by DSM Dyneema. Dyneema is recognised worldwide as the No.1 High Performance yarn.



Construction

The Triple A Plus™ sleeve is produced on conventional style shuttle looms, providing very strong and far superior selvedge on both sides of the sleeve. It is available in two qualities, each having a two ply wall thickness:-

- Heavy Duty, having a nominal 5mm wall thickness
- Light Duty, having a nominal 3mm wall thickness

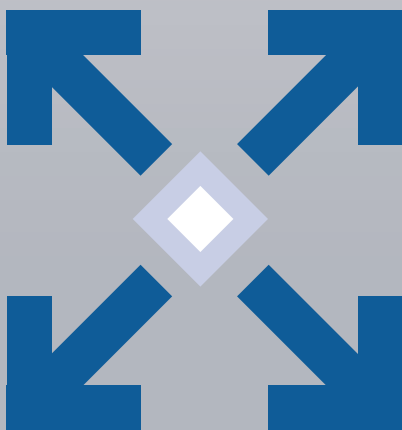

Sleeve Dimension

Sleeve widths currently manufactured range between 50mm and 350mm but can be woven up to 1000mm wide. The thickness and number of plies of the sleeve wall can also be increased to suit specific applications.

APPLICATIONS

SKILLED WORKFORCE, INDUSTRY LEADING EXPERTISE, SPECIALISED PROCESSING EQUIPMENT

Operators worldwide prefer light-weight and easy to manage textile slings, above heavy and load damaging steel slings.

Today's high tenacity fibres enlarge the scope of lifting capacities for textile slings considerably.

Textile slings, up to the highest lifting capacities, and provided with proper protection against cut and abrasion, are user friendly lifting tools for a wide range of applications in the global industrial environment.

- Ports
- Offshore
- Utilities
- Steel Industry
- Automotive
- Heavy Lifting



BENCHMARKING

IT'S TIME TO TAKE ADVANTAGE OF THE BENEFITS OF TEXTILE SLINGS!

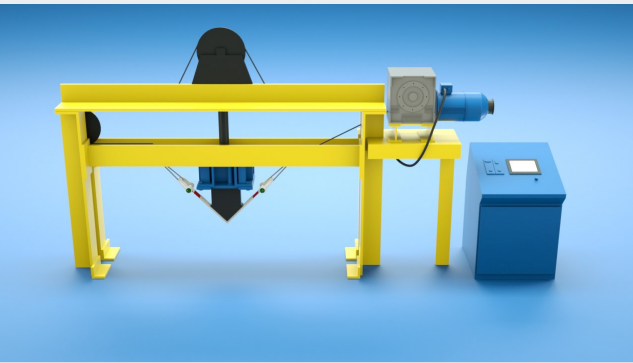

Test Rig

In order to compare and benchmark our products with those of our competitors a testing programme has been established. Four physical tests are conducted: knife abrasion, saw test, metal abrasion and static cut test. Additional information has also been taken into consideration, such as product analysis (yarn material, weight, and weaving constructions), strength determination and homogeneity of the construction.

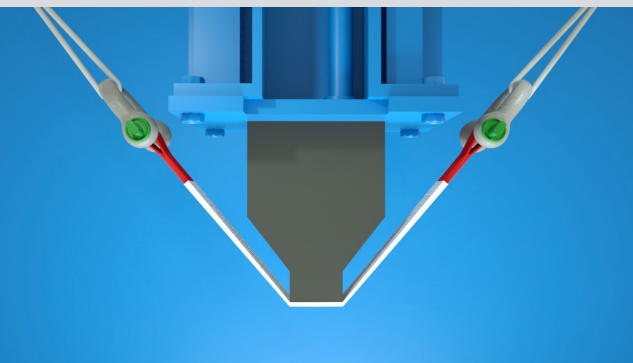

Metal Abrasion Test*

A carrier belt is covered with the protection sleeve/pad and runs at a pre-defined load over a U-beam. The result (number of cycles achieved) is recorded when the protection sleeve/pad is worn and the inner carrier belt is visible.

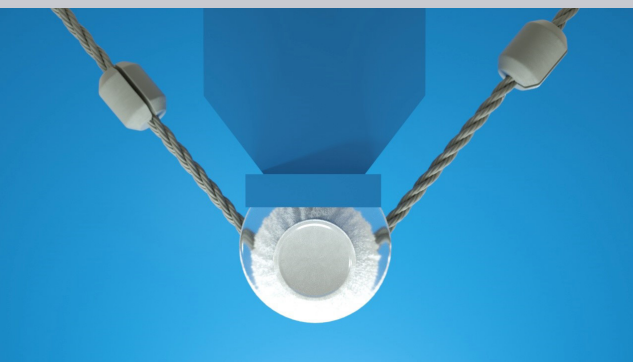

Saw Test*

A steel wire, at a pre-defined load, runs over a carrier belt covered with the protection sleeve or pad. The result (number of cycles achieved) is recorded at the point when the protection sleeve /pad is worn and the inner carrier belt is visible.

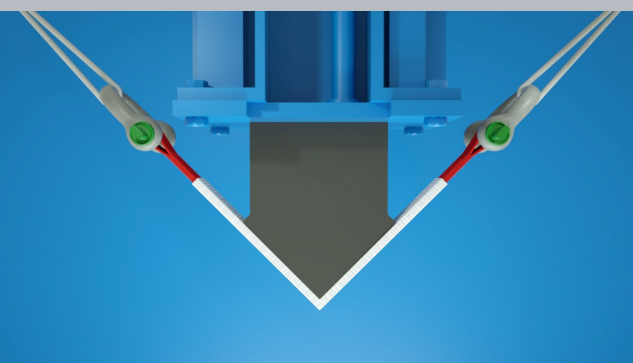

Knife Test*

A carrier belt covered with the respective protection sleeve or pad runs over a sharp edge at a pre-defined load. The result (number of cycles achieved) is recorded at the point when the protection sleeve/pad is worn and the inner carrier belt is visible.

*** For each of the tests a minimum of three runs is made in order to obtain an acceptable average value.**

BENCHMARKING RESULTS

OVERALL RANKING.

THIS IS BASED ON THE FOLLOWING TESTS:

- Static cut
- Knife Abrasion
- Metal Abrasion
- Saw
- Tensile Strength & Homogeneity

	RANKINGS
Triple A Plus™ - HD	100
Product A - HD	37.77
Triple A Plus™ - LD	36.91
Product B - HD	34.19
Product C - LD	23.35
Product D - HD	22.61
Product E - HD	17.57
Product F - LD	13.91
Product G - LD	13.66
Product H - HD	9.33

Test Results

- Our Triple A Plus™ HD sleeve considerably outperforms all tested products.
- Our Triple A Plus™ LD outperforms all tested lighter version sleeves and even some of the solid pads/sleeves for local protection.

The necessity of having the best protection available when using textile slings in order to avoid cut or abrasion at sharp edges of the load is prescribed in worldwide standards and regulations. The comparisons made in our testing programme give a clear picture on the performances of a wide selection of products available on the market. **The outcome is self-explanatory.**

HD = Heavy Duty LD = Light Duty

INTERNATIONAL STANDARDS

IT'S TIME TO TAKE ADVANTAGE OF THE TEXTILE SLING BENEFITS!

Standards and regulations worldwide, such as “Guidance on safe sling use” (Occupational Safety Health Administration – U.S. Department of Labor), EN 1492-1 & EN 1492-2 (European standards for webbing and roundslings) and others, recommend the use of proper protection with textile slings.

The quest for suitable protection sleeves for textile products used in high tensile applications has been a continuous challenge for many years, many products are available on the market.

However, none of them can compete with the superior performance of Triple A Plus™ when it comes to cut and abrasion resistance, enhancing health and safety.





TRIPLE A PLUS™

SAFETY HAS NO PRICE

As a global company we work with clients internationally, our success is driven by our commitment to quality and our ability to deliver innovative textile solutions to market quickly for our customers.

Further research and development to find even better solution are ongoing and will continue until all unlimiting boundaries have been overcome in the most economical and efficient manner.

E sales@marathonbelting.co.uk T +44 (0)1706 657 052

Marathon Belting Limited, Healey Mill, Whitworth Road, Rochdale,
Lancashire OL12 0TF United Kingdom

Disclaimer

All information supplied by, or on behalf of, Marathon Belting Limited in relation to its products and applications is supported by research and believed to be accurate and reliable. However, Marathon Belting Limited assumes no liability whatsoever in respect of application, processing or use made of the aforementioned information or products. It is suggested that the material be thoroughly tested and its suitability for use be determined before final acceptance by the Buyer.

marathon